

FC series

PRODUCT DESCRIPTION

Medium flow intelligent
dispensing peristaltic pump



FC series PRODUCT DESCRIPTION

Medium flow intelligent dispensing peristaltic pump

It is mostly used in testing reagents, oral liquids, veterinary drugs and other pharmaceutical filling, or in chemical, food and other fields

Max flow
2280mL/min

Max speed
600rpm



FC series

FC series is a medium flow intelligent dispensing peristaltic pump, which adopts 3.5-inch touch screen operation, intuitive data display, provides a variety of function settings, has two working modes of transmission and distribution, and can realize repeated timing and quantitative distribution. The stainless steel all-inclusive design is strong Durable, can store 8 sets of filling data, realize fast filling, and support various external control methods such as RS485MODBUS communication protocol.

LCD touch

3.5-inch color LCD, Chinese and English display, Touch screen control

Data storage

8 sets of data can be stored for users

Adapt to multiple pump heads

YZ series, DG series, TX series and other pump heads can be installed, and the pump heads can be cascaded



Flow calibration

With flow calibration function, it is suitable for transferring liquids with higher precision

Multiple modes

It has two working modes of transmission and distribution, and can perform repeated timing and quantitative filling.

Support external control

Support RS485MODBUS communication protocol, analog control, foot switch control

Technical parameter

| Drive model | BT100FC | BT300FC | BT600FC |
|-------------------------|---|--------------------|--------------------|
| Max Speed | 100rpm(reversible) | 300rpm(reversible) | 600rpm(reversible) |
| Max Flow | 480mL/min | 1440mL/min | 2280mL/min |
| Speed resolution | 0.1rpm | 0.1rpm | 0.1rpm |
| Display method | Color LCD display (Chinese and English optional) | | |
| Speed mode | Touch screen adjustment | | |
| Timing range | 0.1s-9999min | | |
| Quantitative range | 0.001mL-9999L | | |
| Filling times | 0-9999t | | |
| Back suction angle | 10°-720° (0° means no back suction) | | |
| Back suction speed | 10-100rpm | 10-300rpm | 10-300rpm |
| Power | <22W | <35W | <50W |
| Drive size | 215x136.4x236.7mm | 215x136.4x236.7mm | 215x136.4x236.7mm |
| Drive weight | 4.64kg | 4.64kg | 4.94kg |
| Power supply | AC220±10% (standard) or AC110V±10% (optional) | | |
| External control method | Start control/direction control/speed control (0-5V, 0-10V, 4-20mA optional) RS485 serial communication | | |

Schematic diagram of structure and function

Pump head → Coupling → Driver

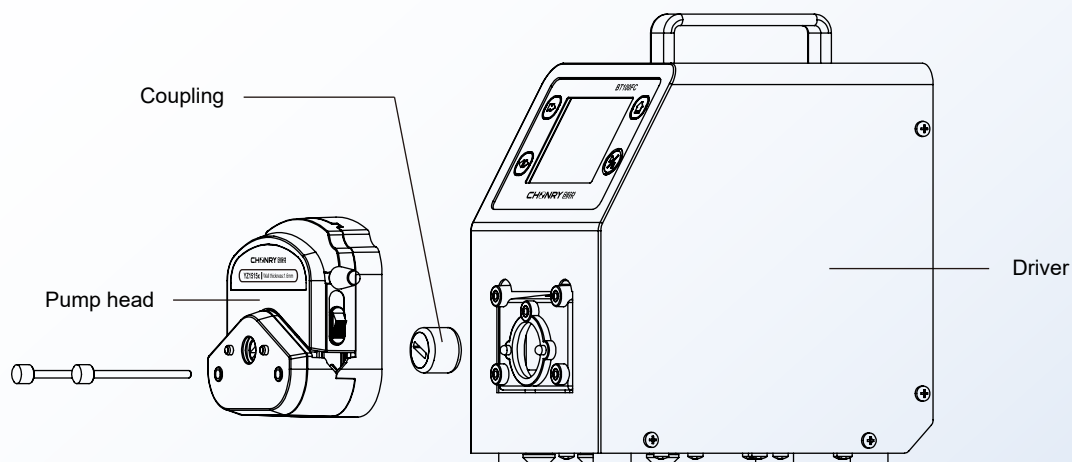

Dimensions

● BT100FC/BT300FC/BT600FC

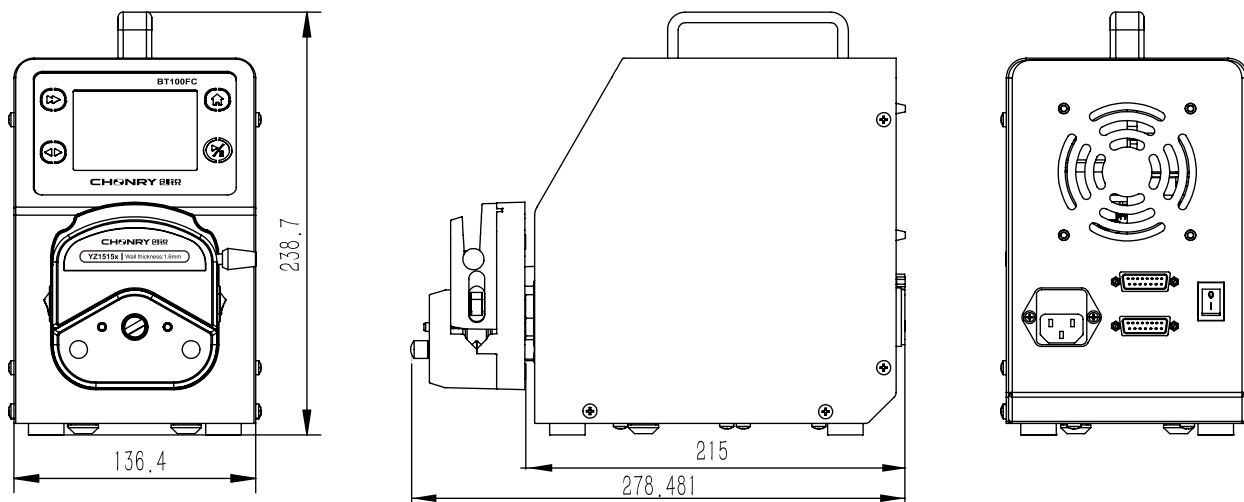

(Unit: mm)

* Technical parameters are subject to change without notice.

CHONRY 创锐

Baoding Chuangrui Precision Pump Co.,Ltd.

Address: NO.369 of HuiYang Street , Baoding 071000,Hebei , China

Mobile: +86 15633705132

Website: <http://www.crpump.com>

Email: support@crpump.com

