

# SG600FC

## PRODUCT DESCRIPTION

Large flow intelligently controlled  
distribution peristaltic pump



## SG600FC

### PRODUCT DESCRIPTION

#### Large flow intelligently controlled distribution peristaltic pump

It is used in large-flow sub-packaging in pharmaceutical factories, chemicals, food, chemical environmental protection, etc.

Max flow  
12000mL/min

Max speed  
600rpm



## SG600FC

SG600FC is a large flow intelligently controlled distribution peristaltic pump. Using a 3.5-inch color LCD touch screen display, the operation is simple and intuitive. It has two working modes: transmission and distribution. It can be intelligently set according to different working needs. The motor has strong torque and is suitable for YZ35, YZ35-13L and YZ35LS pump heads. It can be used for Data storage, supports RS485MODBUS and other remote control modes.

#### Multiple modes

It has two working modes of transmission and distribution, and can perform repeated timing and quantitative filling

#### LCD touch

3.5-inch color LCD, Chinese and English display, touch screen control

#### Adapt to multiple pump heads

YZ35, YZ35-13L, YZ35LS pump heads can be installed, and the pump heads can be cascaded



#### Suction function

The speed angle of reverse operation can be customized to prevent liquid dripping

#### Data storage

8 sets of data can be stored for users

#### Support external control

Support RS485MODBUS communication protocol, analog control, foot switch control

## Technical parameter

Drive model	SG600FC
Max Speed	600rpm (reversible)
Speed resolution	0.1rpm
Max flow	12000mL/min
Speed mode	Touch screen adjustment
Display method	Color LCD display (Chinese and English optional)
Suction angle	10°-720° (0° means no back suction)
Suction speed	10-300rpm
Power supply	AC220V±10% (standard) or AC110V±10% (optional)
Power	<400W
External control interface	DB-15
External control method	Start control/direction control/speed control (0-5V, 0-10V, 4-20mA optional) RS485 serial communication
Drive size	340X238X325.5(mm)
Protection class	IP31 (indoor use, avoid prolonged exposure to UV rays)

## Schematic diagram of structure and function

Pump head screw → Pump head → Coupling → Pump head connection plate → Driver

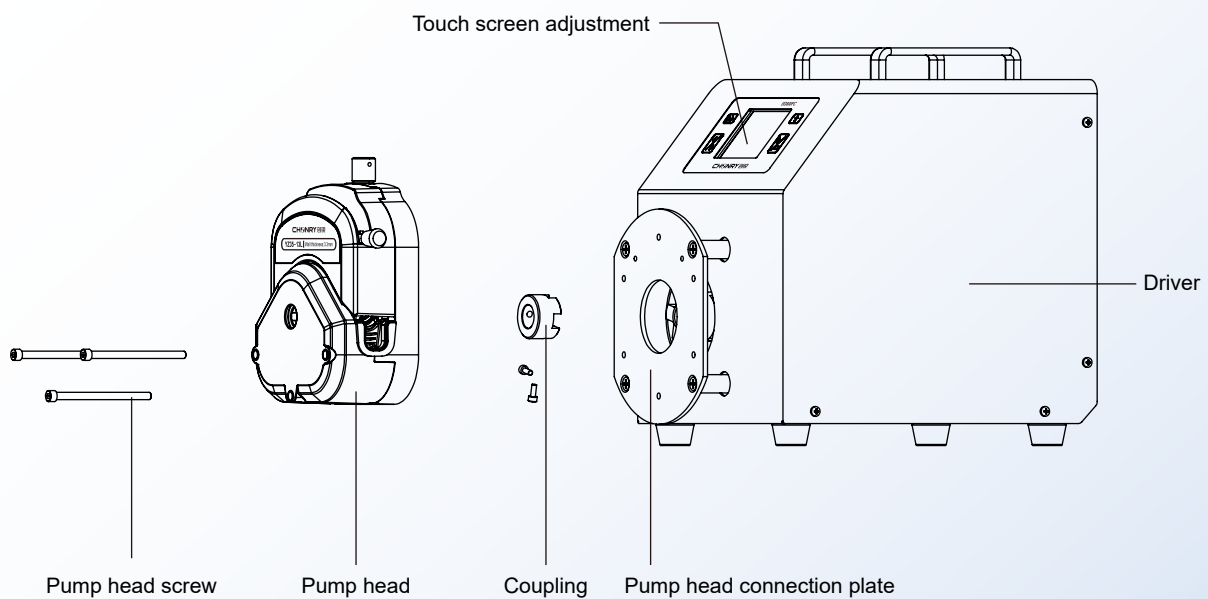

## Dimensions

● SG600FC

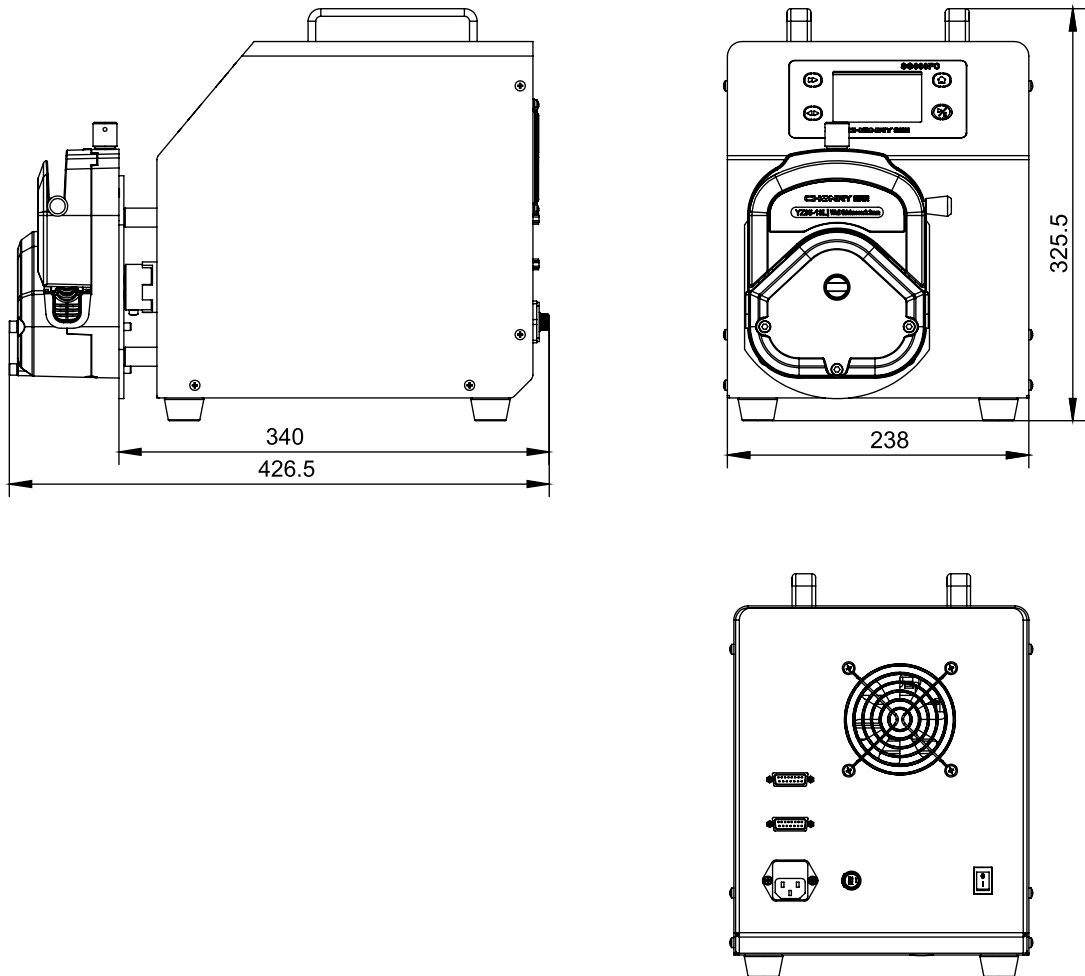

(Unit: mm)

\* Technical parameters are subject to change without notice.

**CHONRY 创锐**

Baoding Chuangrui Precision Pump Co.,Ltd.

Address: NO.369 of HuiYang Street , Baoding 071000,Hebei , China

Mobile: +86 15633705132

Website: <http://www.crpump.com>

Email: [support@crpump.com](mailto:support@crpump.com)

