

ZG600

PRODUCT DESCRIPTION

Large flow digital transmission
peristaltic pump



ZG600

PRODUCT DESCRIPTION

Large flow digital transmission peristaltic pump

Used in food filling, mechanical grinding and polishing liquid, chemical liquid transportation, Large flow transmission such as water treatment

Max flow
12000mL/min

Max speed
600rpm



ZG600

ZG600 is a large flow digital transmission peristaltic pump. It adopts a high-power DC motor with large bidirectional torque. It is suitable for YZ35, YZ35-13L and YZ35LS pump heads. Multiple pump heads can be cascaded. It can be adjusted by digital knobs and uses 3-digit LED to display the current flow rate and speed to meet different application needs.

Powerful

High-power DC motor drive, strong load capacity.

Can be cascaded

Two-way high torque, can cascade multiple pump heads.

Strong and sturdy

The body shell is made of stainless steel, which is sturdy and durable.

High traffic transmission

Equipped with large flow YZ35, YZ35-13L pump head, the maximum transmission capacity is 12L.



Technical parameter

| | |
|------------------|--|
| Drive model | ZG600 |
| Max speed | 600rpm |
| Speed resolution | 1rpm |
| Max flow | 12000mL/min |
| Speed mode | Digital knob to adjust the speed |
| Display method | Three digit LED displays current speed |
| Power supply | AC220V±10% (standard) or AC110V±10% (optional) |
| Power | <400W |
| Drive size | 372X232X225.5 mm |
| Drive weight | 19kg |

Schematic diagram of structure and function

Pump head → Coupling → Pump head connection plate → Driver

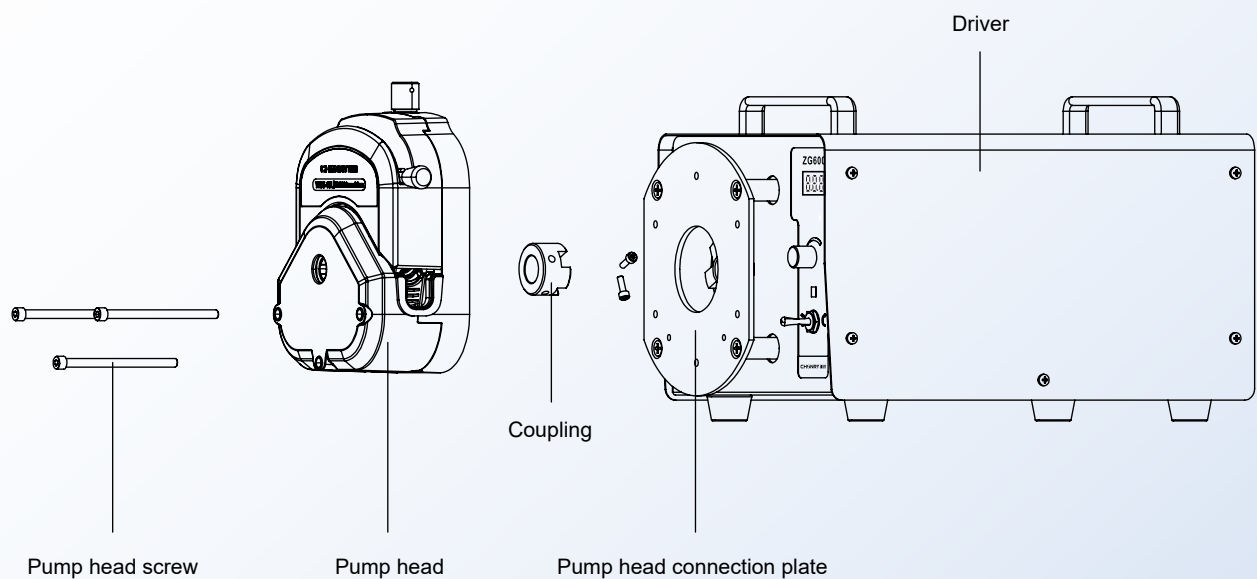

Dimensions

ZG600

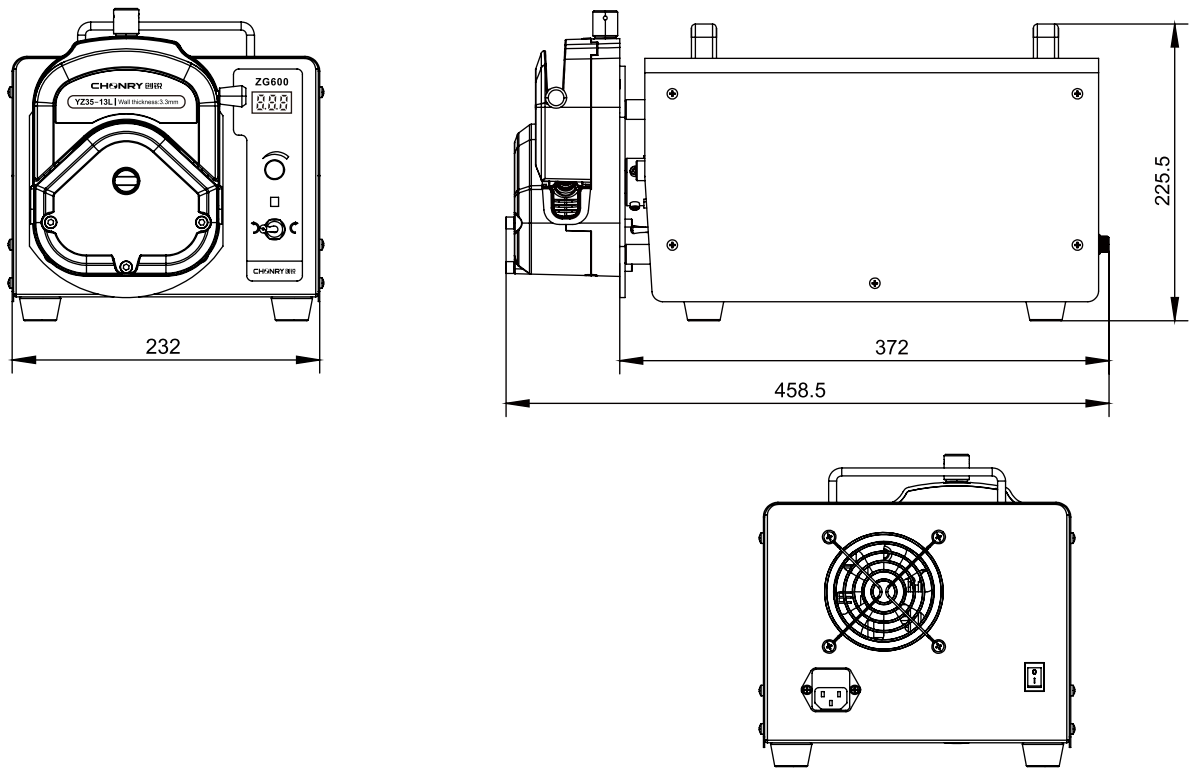

(Unit: mm)

* Technical parameters are subject to change without notice.

CHONRY 创锐

Baoding Chuangrui Precision Pump Co.,Ltd.

Address: NO.369 of HuiYang Street , Baoding 071000,Hebei , China

Mobile: +86 15633705132

Website: <http://www.crpump.com>

Email: support@crpump.com

