



EXPLOSION PROOF DC brushless explosion-proof motor peristaltic pump WFB100/300/600

Applied in chemical industry, medical care
and other industries

Max flow: 12000mL/min

Max speed
600rpm

Technical parameter			
Drive model	WFB100	WFB300	WFB600
Applicable pump head	YZ1515 / YZ2515 / KZ25 / YZ35 / YZ35-13 / TX315		
Max speed	100rpm	300rpm	600rpm
Motor parameters	80W 2000rpm	120W 3000rpm	120W 3000rpm
Gearbox reduction ratio	1:20	1:10	1:5
Max flow	380mL/min	6000mL/min	12000mL/min
Output torque	8N.m	4N.m	2N.m
Speed regulation method	Potentiometer	Potentiometer	Potentiometer
Display method	Potentiometer	Potentiometer	Potentiometer
Operating Voltage	AC100~240V	AC100~240V	AC100~240V
Rated power	<80W	<120W	<120W
Working environment	Ambient temperature 0~40°C, ambient humidity <80%		
drive dimensions	456X300X357(mm)		
Protection level	IP55 (Only motor)		
Electric explosion -proof level	EXDII-B-T4 Gb		

Electric explosion-proof

Motor explosion-proof level is EXDII-B-T4 Gb

Motor protection

Motor protection level is IP55

Potquisher speed regulation

The speed adjustment is easier, fast, and the speed regulation range is wider

Flow range

Multi -pump heads can be installed to adapt to multiple hoses

Desktop structure





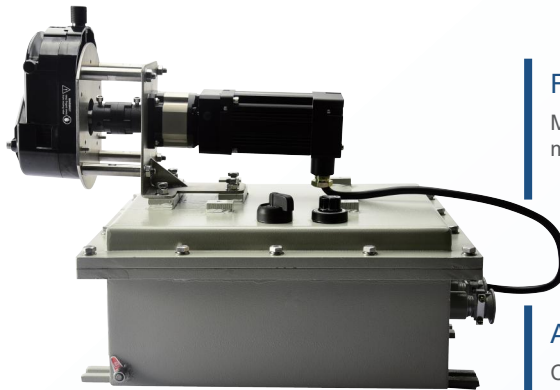

More compact structure, convenient operation and use

Applicable industries

Can be used in chemical industry, medical care and other industries



Pump Head/Hose Specifications

Pump head	Model	Hose Specifications	ID(mm)	Wall thickness (mm)	Max flow(mL/min)	Max speed (rpm)
	YZ1515x	13#	0.8	1.6	42	600
		14#	1.6	1.6	162	
		19#	2.4	1.6	306	
		16#	3.2	1.6	492	
		25#	4.8	1.6	1020	
		17#	6.4	1.6	1740	
	YZ2515x	15#	4.8	2.4	1020	
		24#	6.4	2.4	1740	
	KZ25	15#	4.8	2.4	1800	
		24#	6.4	2.4	3000	
		35#	7.9	2.4	4200	
	YZ35	36#	9.6	2.4	6000	
		73#	9.6	3.3	7400	
	YZ35-13	82#	12.7	3.3	12000	
		73#	9.6	3.3	7400	
	TX315	82#	12.7	3.3	12000	
		13#	0.8	1.6	28	400
		14#	1.6	1.6	106	
		19#	2.4	1.6	227	
		16#	3.2	1.6	399	
		25#	4.8	1.6	830	
17#	6.4	1.6	1400			
		18#	7.9	1.6	1930	

Note: The test environment for flow data is normal temperature and pressure, and the test fluid is water. The values are for reference only, please refer to the actual situation.

Structure diagram

WFB100 structure diagram:

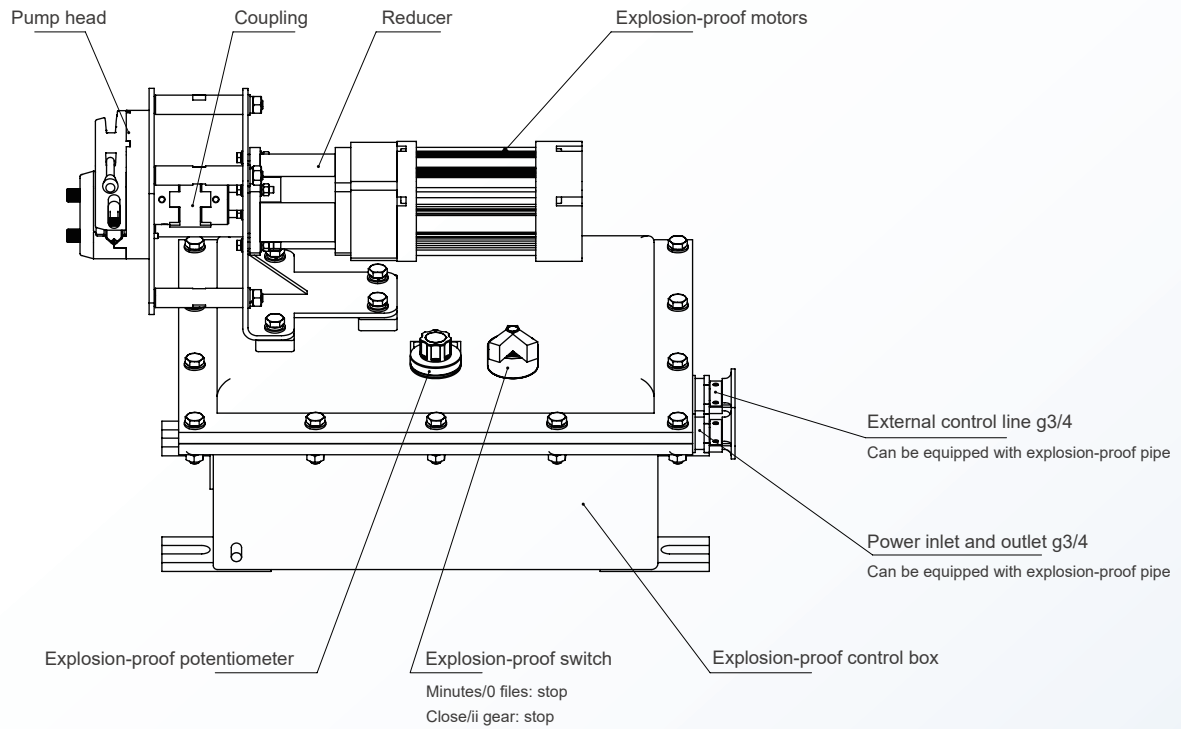

WFB300(WFB600) structure diagram:

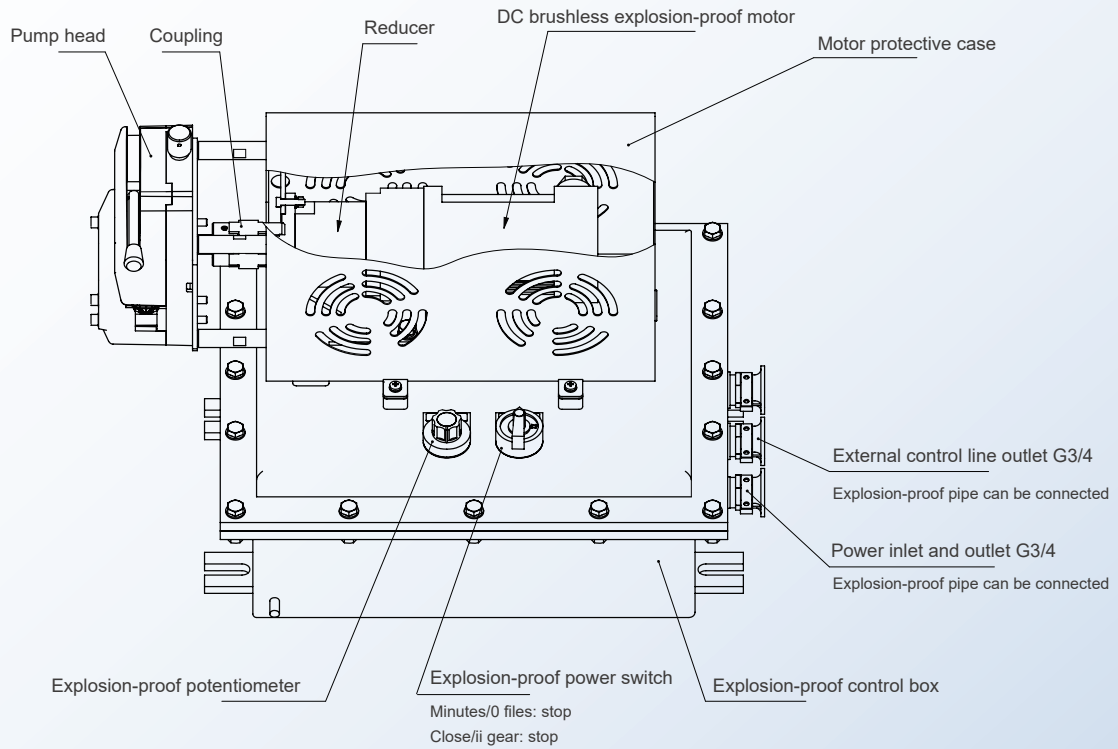

Dimensions of WFB100:

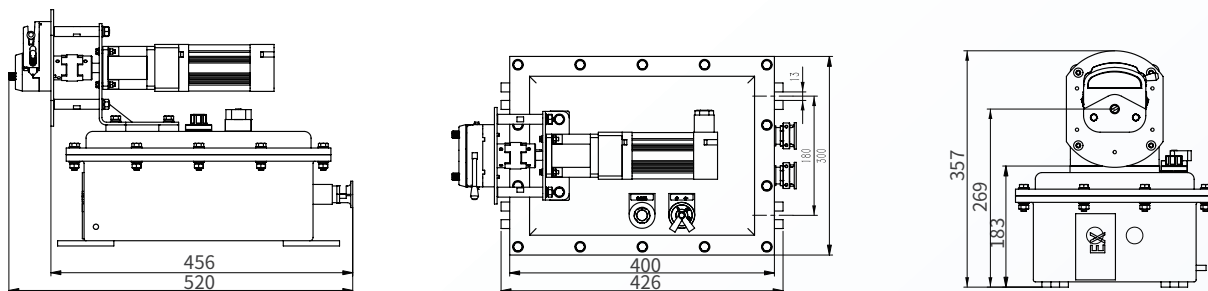

Dimensions of WFB300(WFB600):

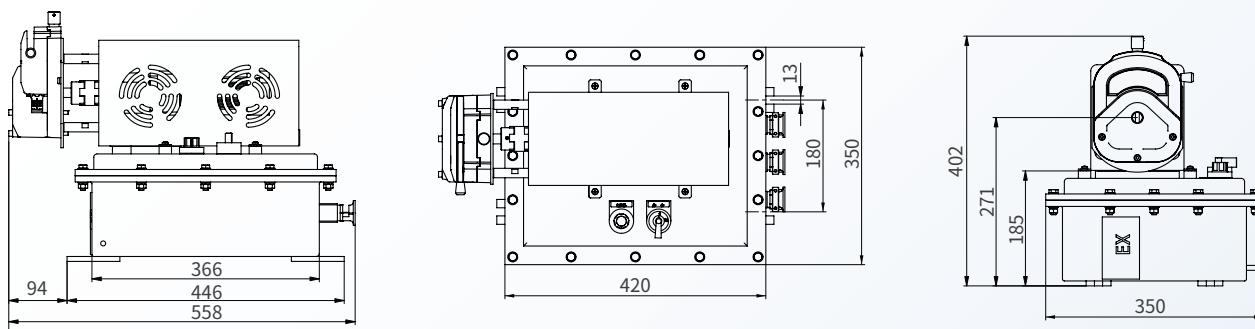

(unit: mm)

CHONRY 创锐

Baoding Chuangrui Precision Pump Co.,Ltd.

Address: NO.369 of HuiYang Street, Baoding 071000, Hebei, China

Mobile: +86 15633705132

Website: <http://www.crpump.com>

Email: support@crpump.com

