

M series

PRODUCT
DESCRIPTION

Digital speed peristaltic pump



M series

PRODUCT DESCRIPTION

Digital speed peristaltic pump

Used in chemical, photovoltaic and other industries, and used in conjunction with filling machines, dispensing machines and other equipment

Max flow
2280mL/min

Max speed
600rpm



M series

The M series is a digital speed type peristaltic pump. It displays the current flow or speed through a 4-digit LED, and can perform liquid volume calibration. It supports RS485/MODBUS communication protocol, and is suitable for YZ, TX, DG series and other pump heads. Various liquid transfer requirements, the knob adjusts the parameters, and the operation is simple and convenient.

Minimalist operation

Low power consumption motor, digital knob is easy to operate, long life

External control operation

With RS485/MODBUS communication protocol, analog control

Flow calibration

Multiple calibrations can be performed to reduce flow rate errors and ensure flow accuracy



Adapt to multiple pump heads

Various pump heads such as YZ series, DG series and TX series can be installed

Power-off memory

Can automatically save the control parameters when the last power failure

Full speed function

Features a convenient full speed button for quickly filling or emptying the hose

Technical parameter

Drive model	BT100M	BT300M	BT600M
Max Speed	100rpm(reversible)	300rpm(reversible)	600rpm(reversible)
Max Flow	480mL/min	1440mL/min	2280mL/min
Drive size	234*154*143mm	234*154*143mm	254*184*150mm
Drive weight	3.98kg	4.3kg	4.8kg
Display method	4-digit LED displays current speed/flow		
Speed mode	Digital knob to adjust the speed		
Power supply	AC220V±10% (standard) or AC110V±10% (optional)		
External control method	Start control/direction control/speed control (0-5V, 0-10V, 4-20mA optional) RS485 serial communication		

Schematic diagram of structure and function

Product structure:

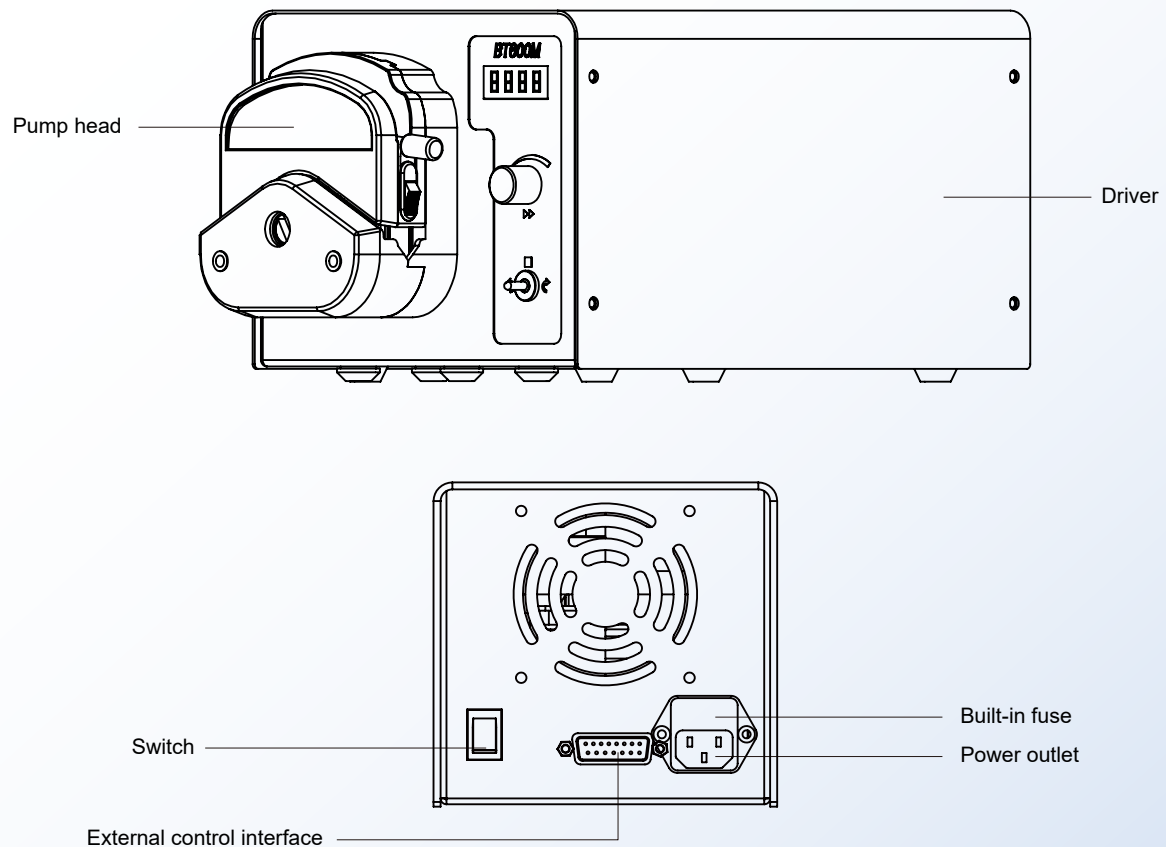

Operation and Display Mode:

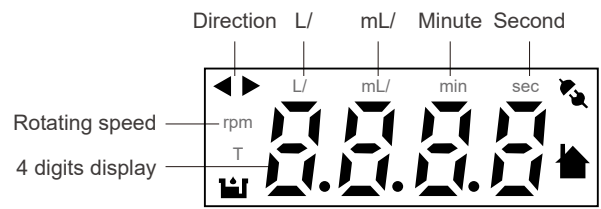
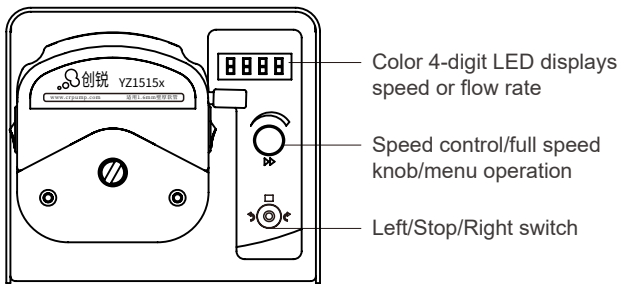

4-LED display, different icons are lit up to show the current working status of the pump

Dimensions

BT100M(BT300M)

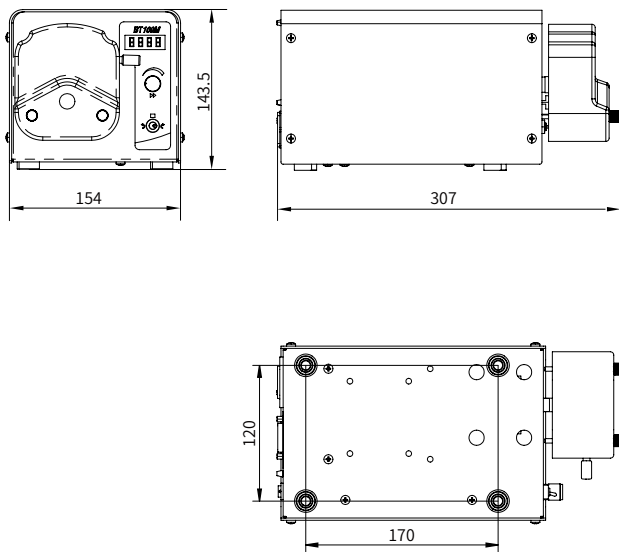

BT600M

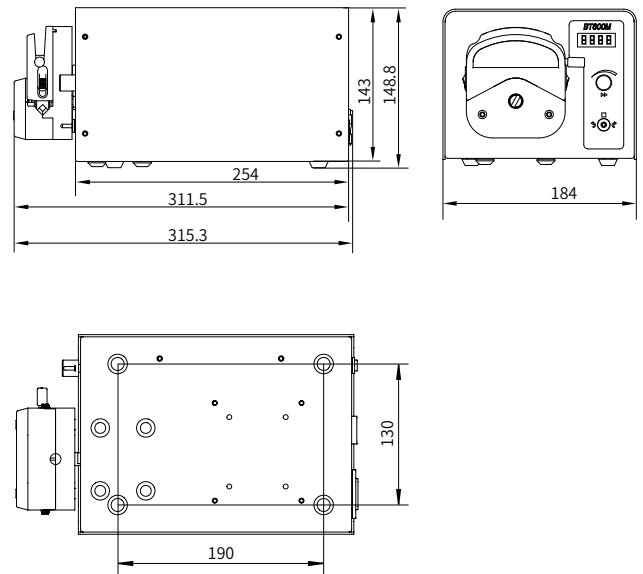

(Unit: mm)

* Technical parameters are subject to change without notice.

CHONRY 创锐

Baoding Chuangrui Precision Pump Co.,Ltd.

Address: NO.369 of HuiYang Street , Baoding 071000,Hebei , China

Mobile: +86 15633705132

Website: <http://www.crpump.com>

Email: support@crpump.com

